

REV.	DESCRIPTION	DRAWN	CHECKED	APPROVED
A	NEW RELEASE	LJH 04/27/05'		

- NOTES:
- MATERIAL
 - INSULATOR:THERMOPLASTIC(UL 94V-0).
 - CONTACT: COPPER ALLOY.
 - SPECIFICATION
 - STORAGE TEMPERATURE:-20-70°C.
 - OPERATING TEMPERATURE:0-85°C.
 - CONTACT RESISTANCE:20mΩ max.(initial).
 - INSULATION RESISTANCE:1000MΩ min.
 - DIELECTRIC WITHSTANDING VOLTAGE:AC 500V PER MINUTE.
 - PART NUMBER: DS1019
 - PRODUCT NUMBER CODE:

DS1019 - X X X X

- CONTACT PLATING
 - Si: SELECTIVE GOLD FLASH
 - 8: FULL GOLD FLASH
 - 2: Gold + Nickel
 - T: Tin
- HOUSING COLOR
 - B: BLACK
- WIDTH
 - N: 7.62mm
 - W: 15.24mm
- No. OF CONTACTS
 - 10 14 16 18
 - 20 24 28 40

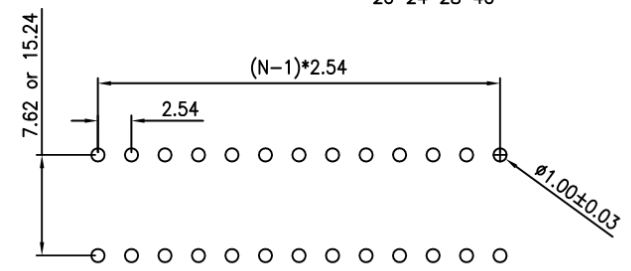

RECOMMEND PCB LAYOUT(TOLERANCE=±0.05)

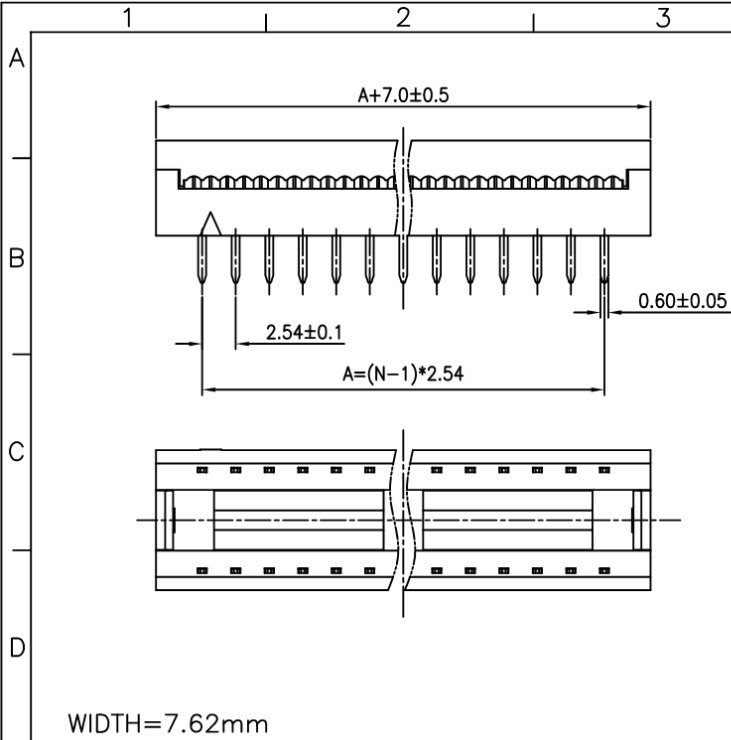

WIDTH=7.62mm

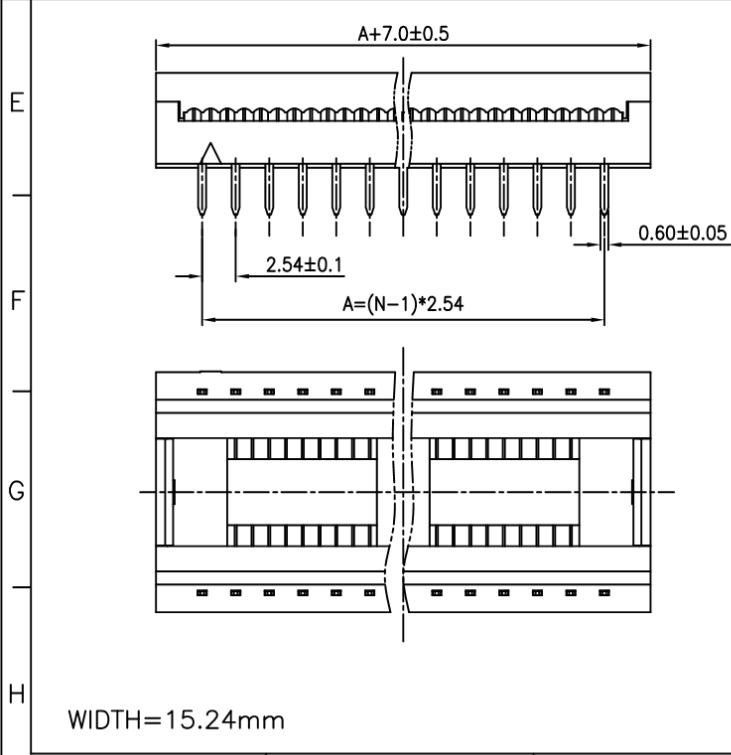

WIDTH=15.24mm

GENERAL TOLERANCE		ANGLE TOLERANCE	
X.	±0.60	X.	±5°
.X	±0.38	.X	±3°
.XX	±0.25	.XX	±2°

DRAWING TYPE	CUSTOMER		
SCALE	1:1	SHEET	1 OF 1
DRAWING NO.	C-DS1019-XXXX		

PROJECTION	TITLE	DIP PLUG CONNECTOR PITCH 2.54mm	
UNITS	mm	SERIES	DS1019 SERIES
SHEET SIZE	A4		

宁波正青电子有限公司
 NINGBO ZHENQIN ELECTRONIC CO. LTD